

DFB Series



In-Line Deflagration Arrester with Replaceable Element

Application:

The Elmac Technologies® DFB series of in-line deflagration arresters are designed to prevent propagation of flames in gas or vapour mixtures. By locating the arrester in close proximity to the potential source of ignition, any flame or explosion is confined to the immediate area. DFB arresters are supplied as complete units ready for direct installation into piping systems. In the context of the Pressure Equipment Directive (PED), Elmac flame arresters are classified as a piping assembly.

Principle of Operation

A flame arrester uses an element with small apertures which allows gas or vapour to pass. If the apertures are smaller than the maximum experimental safe gap (MESG) for the gas or vapour then a flame cannot pass through the arrester, and is subsequently contained or extinguished.

Benefits

- Variety of sizes and materials to suit a wide range of applications
- Replaceable elements
- Bi-directional
- The Elmac technical team can advise on specific location queries

Gas Groups

Elmac in-line deflagration arresters in the DFB series are for use with gases in Groups I, IIA, IIB1, IIB2 and IIB3.

Standards Compliance

All Elmac deflagration arresters have been tested and certified in accordance with national or international standards. Actual device performance is verified in the Elmac Technologies "state of the art" in-house test facility.



Elmac Expertise

Elmac have been manufacturing protection equipment since 1948, and bring enhanced levels of flame and explosion protection to a diverse range of applications. Elmac Technologies offers considerable technical leadership and using test facilities along with CFD capabilities, employs research teams renowned for developing solutions for the most challenging of industrial applications.

DFB Series

In-Line Deflagration Arrester with Replaceable Element

Variations:

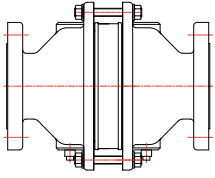

Drain Plugs Fitted

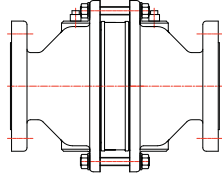

Sockets for Pressure or Thermocouple Tappings

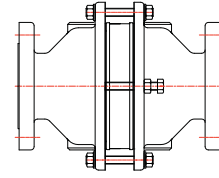

Jacking Screws to Facilitate Element Removal

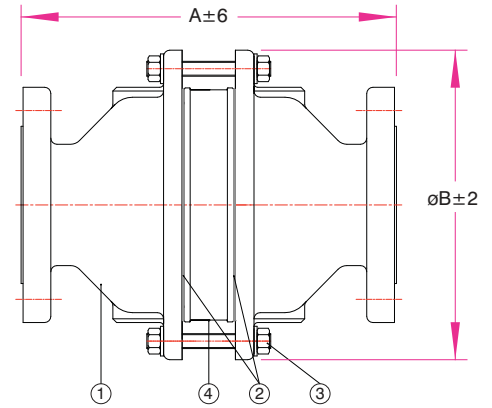

Materials Specifications

Ref	Description	Carbon Steel	Stainless Steel
1	Body	Carbon Steel	Stainless Steel
2	Gaskets	Klingsil C4400	Klingsil C4400
3	Fasteners	Carbon Steel	Stainless Steel
4	Element – housing	Carbon Steel	Stainless Steel
4	Element – core	Stainless Steel	Stainless Steel
4	Element - capscrew	Stainless Steel	Stainless Steel

NB (mm)	25	40	50	80	100	150
Ø Element (mm)	137	137	137	189	237	339
A (mm)	213	213	243	303	313	363
Ø B (mm)	185	185	185	250	310	450
Approx Wt (kg)	16	17	18	29	44	80

Operating Limits*

NB (mm)	25		40		50		80		100		150	
Temperature (°C)	60	150	60	150	60	150	60	150	60	150	60	150
Pressure (bara)	1.6	1.3	1.6	1.3	1.6	1.3	1.6	1.3	1.6	1.3	1.6	1.3
Pipe Length / Diameter Ratio (L/D)	50	40	50	40	50	40	50	40	50	40	50	40

*Pressure and L/D ratio are determined by the operating temperature.

DFB Flow Curves

Air flow at 1 atmosphere (101.325kPa) and 0°C

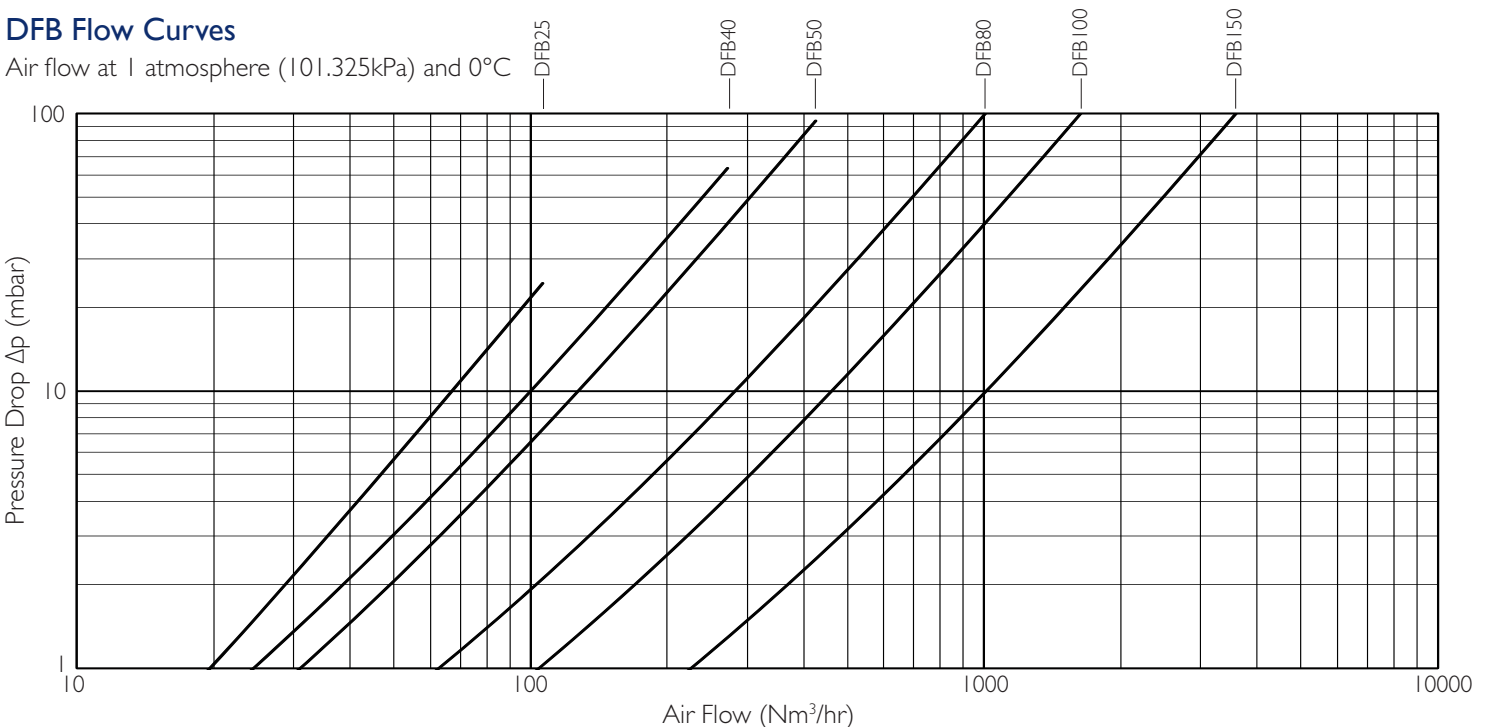

Customer Support

Elmac Technologies Limited

Greenfield, Flintshire, United Kingdom CH8 9DP

T +44 (0) 1352 717600 F +44 (0) 1352 717642 E sales@elmactechnologies.com

Issue No 03 (07/10)

All specifications are correct at time of print, are for guidance purposes only and subject to change without prior notice.



Elmac Technologies®

Innovative Safety Solutions