

Explosion Protection for Storage Tanks



Summary:

Elmac Technologies® supports the recommendations of ISO 28300:2008 and the recent revision of API 2000:2009 Edition 6, which state that it may no longer be acceptable to rely solely on pressure/vacuum relief valves to protect a tank from ingress of a flame front due to external unconfined vapour cloud explosions.

Additional measures should be considered to protect the tank, including the fitting of a flame arrester in combination with the relief valve, installing an inert gas blanketing system or redesigning the tank to eliminate the formation of an explosive atmosphere in the ullage above the liquid. Elmac Technologies® will continue to monitor international standards and review the recommendations below in line with published guidelines and directives.

Storage Tank Design

For new tanks, consideration should be given to eliminating the possibility of the formation of a flammable vapour mixture in the space above the liquid by means of a floating roof design.

For existing tanks, an internal floating roof may be retrofitted to mitigate the risk of explosion although this is an expensive option compared to those described below.

Relief Valves

Elmac Technologies® recommend that a detailed risk assessment has been carried out for each tank installation, taking into account the liquid being stored and the flash-point of the vapour being formed, the storage conditions likely to be encountered (ie temperature and pressure), the potential sources of ignition in the vicinity of the tank (bearing in mind that vapour clouds may be extensive under favourable conditions) and the prevailing geographical and meteorological conditions.

Relief Valves cont.

If this risk assessment confirms the risk of an explosion to be negligible, then a pressure/vacuum relief valve may be considered as a suitable device to prevent the flashback of an unconfined vapour explosion. alternative to a flame arrester.

However, relief valves can (and do) encounter operating problems, usually resulting from inadequate maintenance. It is possible, for example, that the valve pallets may stick in an open position.

Under these conditions, any protection that a valve may offer against flame transmission will be compromised and the formation of a vapour cloud becomes more likely.

Accordingly, to provide continued tank protection, every relief valve must be regularly maintained in accordance with a written and applied maintenance schedule.

Explosion Protection

Explosion Protection for Storage Tanks

Flame Arresters

It is possible that a flame arrester element may become fouled by solids, such as dust which is prevalent in dry/arid climates, or by viscous liquids in the process stream.

As flow resistance will increase if an arrester element becomes fouled, this creates the potential for elevated pressures in a storage tank during filling, or to produce a vacuum in the tank during the emptying operation.

Because of the ever present drive to reduce costs, tanks are being constructed from thinner section wall supported by external buttresses to provide strength. Whilst this may be satisfactory for overpressure conditions, tanks are increasingly susceptible to collapse under vacuum.

Flame arresters cannot be treated as “fit and forget” devices and Elmac Technologies® maintenance instructions make it very clear, as with relief valves, that regular inspection of the elements is required.

If this is carried out at a frequency which is suited to the operating risks, then this problem should not arise. As an extra precaution, it is possible to fit in-line and/or end-of-line filters to prevent ingress of dust into the arrester element.

Taking maintenance and tank protection into consideration, Elmac Technologies® recommend that individual flame arresters and relief valves should be installed together (see Figure 1) rather than single combination units.

The reason for this is that the flame arrester offers tank protection during valve maintenance and, should the arrester element require cleaning or replacing, this can be achieved with the relief valve in situ, minimising the risk of explosion..

Inert Gas Blanketing

If flame arresters are unsatisfactory, then tank operators may have to consider installing more expensive inert gas blanketing systems in order to satisfy the guidance of ISO 28300:2008 and API 2000:2009.

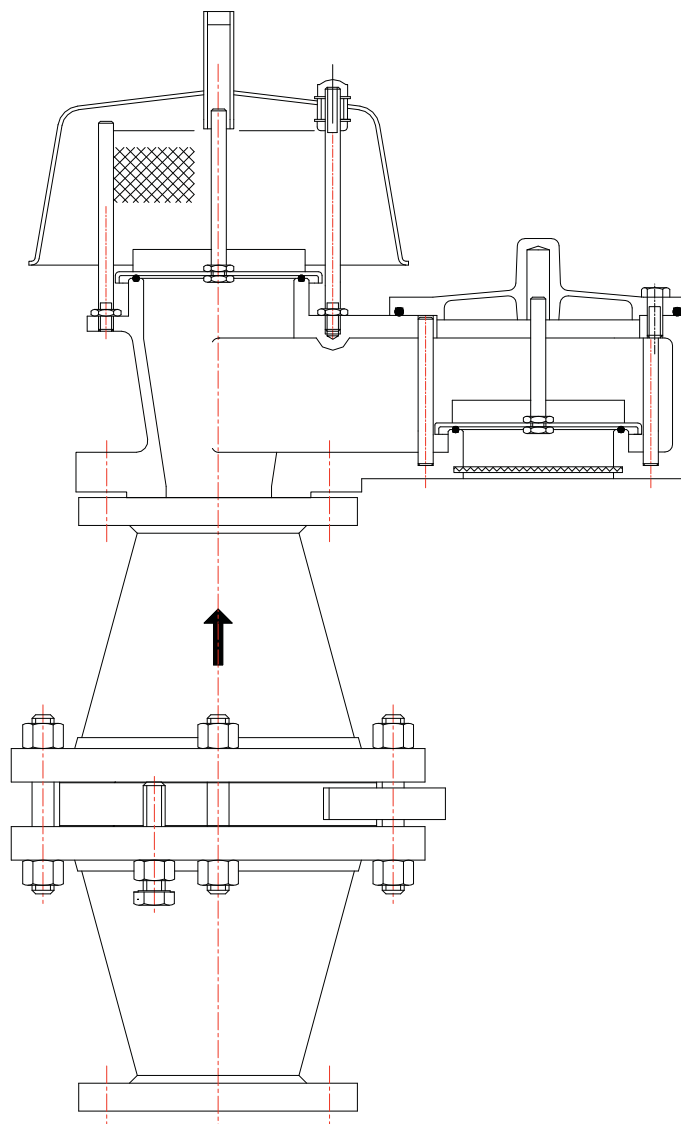

Figure 1. Schematic drawing of individual flame arrester and relieve valve installed together.

Elmac Expertise

Elmac have been manufacturing flame arresters since 1948, and bring enhanced levels of flame and explosion protection to a diverse range of applications.

Elmac Technologies® offers considerable technical leadership and using test facilities along with CFD capabilities, employs research teams renowned for developing solutions for the most challenging of industrial applications.

Customer Support

Elmac Technologies Limited

Greenfield, Flintshire, United Kingdom CH8 9DP
T +44 (0) 1352 717600 F +44 (0) 1352 717642 E sales@elmactechnologies.com