

# CE-IB Det. Series



## In-Line Unstable Detonation Arrester with Replaceable Element

### Application:

The Elmac Technologies Limited, CE-IB Det. in-line unstable detonation arresters are designed to prevent propagation of detonations in gas or vapour mixtures. Detonation arresters are specifically designed for pipelines with a significant distance between the ignition source and the arrester; or for use where the pipe is rough, bent, obstructed or has section changes. CE-IB Det. arresters are supplied as complete units ready for direct installation into piping systems.

### Principle of Operation

A detonation arrester uses a crimped ribbon element with small apertures which allows gas or vapour to pass. The elements are designed so that they both attenuate the detonation shock wave, and extinguish the flame. Elmac detonation arresters are always designed to deal with unstable detonations. In the context of the Pressure Equipment Directive (PED), Elmac detonation arresters are classified as a piping assembly.

### Benefits

- Suitable for unstable detonations, stable detonations and deflagrations
- Large variety of sizes and materials to suit a wide range of applications
- Variants available for different operating temperature ranges
- Options available for sour environments
- Replaceable elements
- Bi-directional
- The Elmac technical team can advise on specific location queries

### Gas Groups

Elmac detonation arresters in the CE-IB range are for use with gases in Groups IIA, IIB1, IIB2 and IIB3.

### Standards Compliance

All detonation arresters have been tested and certified in accordance with national or international standards.

Actual device performance is verified in the Elmac Technologies "state of the art" in-house test facility.



### Elmac Expertise

Elmac have been manufacturing flame arresters since 1948, and bring enhanced levels of flame and explosion protection to a diverse range of applications. Elmac Technologies offers considerable technical leadership and using test facilities along with CFD capabilities, employs research teams renowned for developing solutions for the most challenging of industrial applications.

# CE-IB Det. Series

## In-Line Unstable Detonation Arrester with Replaceable Element

### Variations:

Flange fixing (ANSI 150, or PN16), Female fixing (BSP/NPT),  
Male fixing (BSP/NPT).

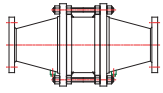

Drain Plugs Fitted

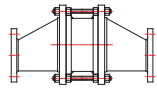

Eccentric Reducers

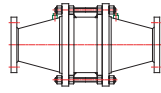

Sockets for Pressure or Thermocouple Tappings

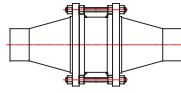

Female Fixing (BSP/NPT)

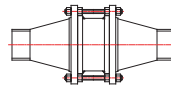

Male Fixing (BSP/NPT)

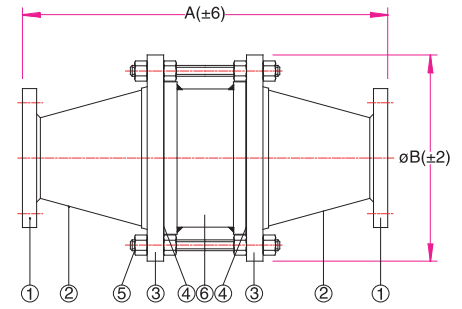

### Material Specifications

Ref	Description	Carbon Steel Models	Low Temp Carbon Steel Models	Stainless Steel Models	Hastelloy Models
1	Fixing flanges	Carbon Steel	Low Temp Carbon Steel	Stainless Steel	Hastelloy
2	Body	Carbon Steel	Low Temp Carbon Steel	Stainless Steel	Hastelloy
3	Element flanges	Carbon Steel	Low Temp Carbon Steel	Stainless Steel	Hastelloy
4	Gaskets	Klingsil C4400	Klingsil C4400	Klingsil C4400	Klingsil C4400
5	Fasteners	Carbon Steel	Stainless Steel	Stainless Steel	Hastelloy
6	Element - housing	Carbon Steel	Low Temp Carbon Steel	Stainless Steel	Hastelloy
7	Element - core	Stainless Steel	Stainless Steel	Stainless Steel	Hastelloy
8	Element - periphery	Stainless Steel	Stainless Steel	Stainless Steel	Hastelloy

### Dimensions

NB (mm)	15	20	25	32	40	50	65	80	100	125	150	200
ø Element (mm)	80	80	80	80	80	100	150	150	200	250	300	400
A (±2) mm	375	379	367	371	371	403	509	493	529	706	766	1082
øB (±5) mm	190	190	190	190	190	229	254	279	343	406	483	597
Approx Wt (kg)	18	19	20	21	23	30	49	50	73	158	194	320

### CE-IB Det. Flow Curves

Air flow at 1atmosphere (101.325kPa) and 0°C

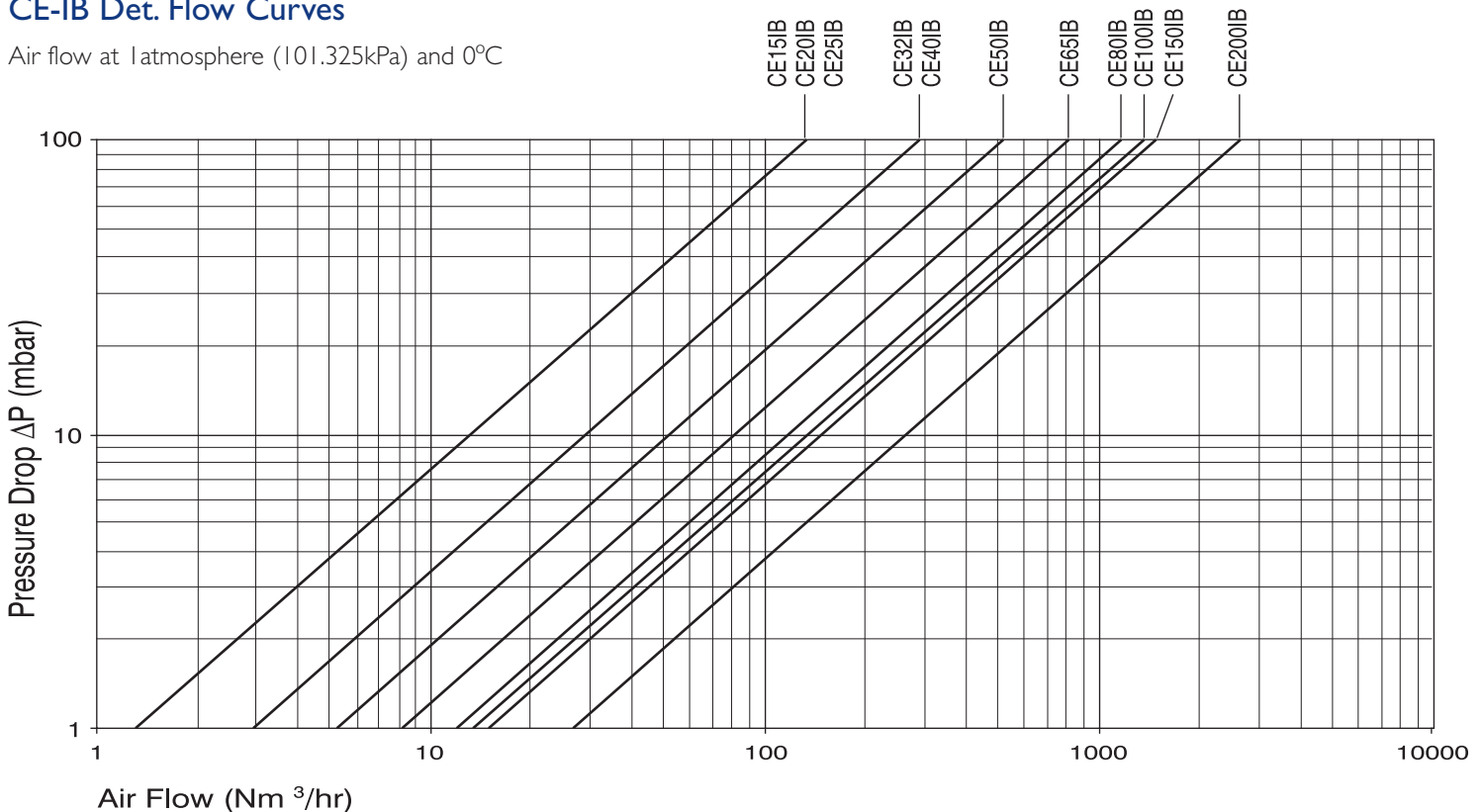

### Customer Support Team

**Elmac Technologies Limited**  
Greenfield, Flintshire, United Kingdom CH8 9DP  
T +44 (0) 1352 717600 F +44 (0) 1352 717642 E sales@elmactechnologies.com



Innovative Safety Solutions